

No. 18 10-LITRE DOUGH MIXER

OPERATING AND SERVICING MANUAL



IMPORTANT: documents in this manual to be kept carefully:

- « CE » DECLARATION OF COMPLIANCE
- GUARANTEE CERTIFICATE

Translation of the original version



Coffee grinders - Fruit juicers - Mixers - Blenders - Drink dispensers - Planetary mixers
Cheese graters - Ice crushers - Miners - Vegetable slicers – Dough mixer
Moulins à café - Presse-fruits - Mixers - Blenders - Distributeurs de boissons - Batteurs
mélangeurs - Pétrin - Râpes à fromage - Broyeurs à glaçons - Hache-viande - Coupe-légumes

MODELES DEPOSES FRANCE ET INTERNATIONAL
INTERNATIONALLY PATENTED MODELS



CONTENTS

“CE” DECLARATION OF COMPLIANCE.....	4
IMPORTANT SAFEGUARDS	5
<i>INSTALLATION AND HANDLING.....</i>	<i>5</i>
<i>IMPROPER USE</i>	<i>5</i>
<i>ELECTRICAL CONNECTION</i>	<i>6</i>
<i>COMMISSIONING</i>	<i>6</i>
<i>RECYCLING THE PRODUCT AT THE END OF ITS SERVICE LIFE.....</i>	<i>7</i>
YOUR No. 18 DOUGH MIXER.....	8
<i>DESCRIPTION OF THE MACHINE</i>	<i>8</i>
OPERATION OF THE MACHINE	9
<i>START-UP</i>	<i>9</i>
Assembly and preparation	9
<i>OPERATION.....</i>	<i>9</i>
Adjust the brake so that the dough mixing proceeds correctly:	9
<i>STOPPING OF THE MACHINE.....</i>	<i>9</i>
<i>FRENCH BREAD</i>	<i>10</i>
<i>CLEANING</i>	<i>10</i>
SAFETY SYSTEMS / MAINTENANCE	11
<i>MOTOR OVERLOAD SAFETY SYSTEM.....</i>	<i>11</i>
<i>TOOL ACCESS SAFETY SYSTEM.....</i>	<i>11</i>
<i>MAINTENANCE.....</i>	<i>12</i>
Spare parts:	12
TROUBLE-SHOOTING.....	13
The machine does not start	13
The machine stops at an overload.....	13
The motor makes noise	13
The bowl does not rotate.....	13
The bowl rotates too fast.....	13
The machine stops while mixing	13
Flour falls out of the bowl.....	14
TECHNICAL CHARACTERISTICS OF THE MACHINE.....	15
<i>TECHNICAL CHARACTERISTICS.....</i>	<i>15</i>



<i>ELECTRICAL WIRING DIAGRAMS</i>	16
<i>Wiring diagram 100-120V~ 50/60Hz</i>	16
<i>Wiring diagram 220-240V~ 50/60Hz</i>	17
<i>Component identification table</i>	18
Figures	19
WARRANTY CERTIFICATE	21
APPLIANCE IDENTIFICATION PLATE	21





“CE” DECLARATION OF COMPLIANCE

Z
II

SANTOS sas - 140-150, Av. Roger SALENGRO 69120 VAULX-EN-VELIN (LYON)
FRANCE

declares that the appliance intended for the professional market described below:

Description: **DOUGH MIXERS**
Type number: **18**

complies with:

- the statutory provisions defined in appendix 1 of the European "machines" directive n°2006/42/CE and the national legislation transposing it
- the statutory provisions of the following European directives and regulations:
 - N° 2006/95/CE (low voltage directive)
 - N° 2004/108/CE (EMC directive)
 - No. 2002/95/CE (RoHS directive)
 - No. 2002/96/CE (WEEE directive)
 - N° 1935/2004/CE (regulation) relating to materials and articles intended to come into contact with foodstuffs

Harmonised European standards used to give presumption of conformity with the essential requirements of the above-mentioned directives:

- **NF EN 453+A1: 2010**, Food processing machinery – **DOUGH MIXERS** - Safety and hygiene requirements.
This European standard is a type-C standard as defined in EN ISO 12100. When the provisions of this type-C standard differ from those stated in the type-A or B standards, the provisions of the type-C standard override the provisions of the other standards. This standard provides the means to comply with the requirements of the "machines" directive n°2006/42/CE, (see appendix ZA)
- NF EN ISO 12100 -1 and 2:2004: Safety of machinery - General principles for design
- NF EN 60204-1: 2006 : Safety of machinery - Electrical equipment of machines-General requirements
- NF EN 1672-2: 2005, Food processing machinery – Basic concepts – Hygiene requirements
- NF EN 60335-1: 2013: Household and similar electrical appliances. Safety.
- NF EN 60335-2-64 :2004: Particular requirements for commercial electric kitchen machines

Drawn up in VAULX-EN-VELIN on: **01/01/2014**

Signatory's position: **CHIEF EXECUTIVE OFFICER**

Signatory's name: **Aurélien FOUQUET**

Signature:

IMPORTANT SAFEGUARDS

When using, cleaning or maintaining the machine, always follow these instructions:

Read all instructions

Note: To facilitate understanding of the following paragraph, consult the diagrams located at the end of the manual.

These photographs and images are given as an example and are non-contractual. Santos reserves the right to change them at any moment.

INSTALLATION AND HANDLING

Just one person is required for handling the appliance. For ease of use, it is recommended that the machine is placed on a table or work surface so as to have the control panel in front of you (recommended height: 90 cm, to be adapted to suit the user).

CAUTION:



For any handling operation, including unpacking of the machine, do not hold or lift the machine by the protective cover (1). (fig. A)

CAUTION:



Check that the cover (1) is in the closed position before plugging the power cord (10) into the mains socket (fig. C).

IMPROPER USE

This machine is exclusively meant to be used by qualified personnel in the context of a professional job and NOT in the context of private work.

Any use of the machine which does not observe the instructions in this manual must be considered as unsuitable and thus dangerous.



1. Do not use this machine for mixing anything other than foodstuffs.
2. Do not use this machine for mixing frozen products.
3. Do not overload the machine beyond the limits of its bowl capacity, i.e. 2.5 kg of flour plus 1.5 kg of water (4 kg of stiff dough).
4. Cleaning with a water jet or under pressure is not allowed.
5. For electrocution risk protection reasons, never plunge the base into water or any other liquid.
6. Unplug the appliance before carrying out any work on it: cleaning, maintenance or repair.

7. The use of spare parts other than certified SANTOS original parts is prohibited.
8. Never use the appliance if the power cord is damaged. It must be replaced by either a SANTOS approved dealer or a person with similar qualifications to avoid any danger.
9. Connect several appliances to the same power socket.
10. Use the appliance outdoors.
11. Never place the appliance close to or on a source of heat.
12. This appliance is a professional machine designed exclusively for professional use. It is not designed for household use.
13. This appliance is not designed for use by people (including children) whose physical, sensorial or mental capacities are impaired or by people with no experience or knowledge, unless they have been supervised or given training in the use of the appliance beforehand by a person responsible for their safety.
Supervise children to ensure they do not play with the appliance.

ELECTRICAL CONNECTION

- The electric power supply for the machine is available in 2 single-phase voltages:
 1. 110-120 V 50/60 Hz: Model 18V1
 2. 220-240 V 50/60 Hz: Model 18

Line protection: the machine should be connected to a standard 2-pole + earth electric socket. The system should be fitted with an RCD and a fuse rated at 16A. **The appliance must be earthed** (fig. B).

CARE:

- Before connecting the machine, check that the mains electrical voltage is the same as the voltage for your appliance. Its value is shown:



- either on the identification plate (**11**) under the machine.
- or on the identification plate on the last page of this manual.

- If the power cable (**10**) is damaged, it should be replaced by a SANTOS approved dealer, SANTOS or a person with similar qualifications to avoid any danger.

COMMISSIONING

Carefully clean the parts entering into contact with the foodstuffs (fig. B).

- Clean the protective cover (**1**), the bowl (**3**) and the mixing fork (**7**) using a non-abrasive sponge and a standard washing liquid.

RECYCLING THE PRODUCT AT THE END OF ITS SERVICE LIFE



This equipment is marked with the selective sorting symbol relating to wastes from electrical and electronic equipment. It signifies that this product should be taken over by a selective collection system conforming to the Guideline 2002/96/EC (WEEE) – part Professional Equipment – so that it can be either recycled or dismantled in order to reduce any impact on the environment.

For more information, please contact your Retailer or the SANTOS.

For eliminating or recycling components of equipment, please contact a specialized company or contact SANTOS.

The electronic products not undergoing a selective sorting are potentially dangerous for the environment.

The damaging materials should be eliminated or recycled according to the regulations in force.



YOUR No. 18 DOUGH MIXER

- This sturdily built cast aluminium dough mixer with a stainless steel bowl and mixing fork and a polycarbonate protective cover is designed for professional use: HOTELS, RESTAURANTS, COMMUNITIES, PIZZERIAS, BAKERIES, MANUFACTURERS OF DIETING PRODUCTS, etc.
- The dough mixer is particularly suitable for preparing stiff dough such as that used for bread, tart bases and pizzas. Its bowl has a capacity of 10 litres and can be used for preparing 4 kg of stiff dough (2.5 kg of flour). *DO NOT overload the mixer with a quantity of more than 4 kg !*
- The No. 18 dough mixer is ideal for preparing all types of pastries, minces, etc.
- During operation, the tool rotates at constant speed and rotation of the bowl is ensured by mixing of the dough. A brake adjustable by a knob (5) can be used to set the rotation speed of the bowl during mixing.

2

DESCRIPTION OF THE MACHINE

1. Tilting protective cover (1) (fig. B)
2. Lock pin (2) for tilting of the reduction gear (6) and fork assembly, after the two screws (4) have been loosened.
3. Two screws for locking the reduction gear and fork (7) assembly.
4. On/Off luminous switch (13) operating without voltage with a manually reset thermal circuit breaker.
5. Brake adjusting knob (5) to set the bowl rotation speed.

OPERATION OF THE MACHINE

START-UP

Assembly and preparation

(fig. B)

1. **The protective cover (1)** is hinged.
The lower position is the work position.
The upper position gives complete access to the bowl and fork. In this position:
2. **The reduction gear (6) is fitted around the motor shaft**; the reduction gear is tightened by the 2 screws (4). The stable positions are ensured by a pin (4).
3. **Installation of the bowl (3)**: (fig. D) The bowl rotates freely around the base pin and can be removed by raising it (first raise the cover (1), the reduction gear (6) and the fork (7))
4. **Installation of the fork (7)**: (fig. E) protective cover (1) raised, reduction gear (6) up, install the fork (7) so that the bayonets are aligned with the fork groove.

OPERATION

1. Switch on the power by plugging the power cord (10) into the mains.
2. Place the fork (7) on the reduction gear output shaft (align the bayonet with the groove).
3. Swivel the reduction gear (6) and align it with its lower position (fork in the bowl).
4. Lock and fasten the reduction gear by the screws (4).
5. Fill the bowl (3) with the necessary ingredients (*see the counter-indications*).
6. Lower the protective cover (1).
7. Actuate the On/Off switch (13) to begin the dough mixing.
8. The bowl is not driven by the motor and it is advisable to help it to turn by hand until all the flour is wet.

Adjust the brake so that the dough mixing proceeds correctly:

- If the bowl is too free, it turns too fast and the fork tends to make a hole in the dough instead of mixing it. Tighten the brake (5)
- If the bowl is too tight it turns too slowly and the dough tends to climb to the top of the fork. Loosen the brake (5)

When the dough is mixed, loosen the two screws (4), raise the fork and remove it if necessary.

The bowl is removed from its pin and can be easily transported.

STOPPING OF THE MACHINE

The machine is stopped by:

1. actuating the On/Off switch (13),
2. or raising the protective cover (1),
3. or unplugging the power cord (10) from the mains.

FRENCH BREAD

To mix 4 kg of stiff dough, use: 2.5 kg of baker's flour, 1.5 l of water (60 % of the weight of the flour), 45 g of salt (30 g per litre of water), 45 g of baker's yeast (30 g per litre of water).

Very important: the temperature of the water, in normal ambient conditions, must be about 14 °C. Use warmer water if the ambient temperature is lower (e.g. for an ambient temperature of 5°C, use water at 30°C).

Slowly mix the flour, the water and the yeast; knead for 10 to 12 min. Add the salt only 3 minutes before the end: the dough obtained must be "STIFF" (about 24°C after mixing).

Allow the dough to rest after mixing for about 30 minutes minimum.

Shape your loaves and allow them to rise for about 2 hours.

For baking, use an appropriate oven and load at 220°C.

The duration of the baking will be 1 hour per kg of bread (20 min. for a 300 g baguette).

CLEANING

IMPORTANT:



- In all cases, stop the machine and unplug its power cord (10).

It is advisable to clean the machine as soon as the mixing is completed.

Cleaning will be easier before the foodstuffs dry in the bowl (3), on the protective cover (1) or on the mixing fork (7).

The base (8) should be cleaned with a damp sponge and then dried.



SAFETY SYSTEMS / MAINTENANCE

Z

MOTOR OVERLOAD SAFETY SYSTEM

The On/Off switch (13) switches automatically to « 0 ».

REMARKS: Mixing dough requires heavy work from the motor. It is thus normal for the motor to heat up. It has been designed for the purpose. It is however protected by a thermal circuit-breaker built into the On/Off switch (13). Should there be an overload or jamming, for example, this circuit-breaker will trip.

In this case, remove the cause of the trouble and allow the motor to cool, **wait for a few moments for automatic resetting of the circuit breaker** then operate the On/Off switch to start the motor.

If the problem persists, switch off the machine (unplug the power cord from the mains (10)) and call a technician of the maintenance department or contact an approved SANTOS retailer.

TOOL ACCESS SAFETY SYSTEM

The machine can start only if the protective cover (1) is lowered.

- the opening of the cover (1) stops the machine and all its moving parts.
- Interruption of the power supply stops the machine.

Restarting of the machine requires a fresh action on the switch (13).

For safety reasons, it is prohibited to insert a finger or part of one's hand into the opening for adding ingredients (Fig. F).

MAINTENANCE

Before carrying out any work on the machine, it must be unplugged from the mains and the motor start capacitor discharged.

Discharging the capacitor:



Using a screwdriver with an **insulated handle**, touch the 2 capacitor connections (9). You should see an electric arc which means that the capacitor has been discharged.

Spare parts:



IMPORTANT: Use of spare parts other than certified original SANTOS parts is prohibited

This machine requires no specific maintenance. The bearings are lubricated for life. If work is required to replace worn parts such as the grindstones or the electric or other components, refer to the parts list (see exploded view at the end of the manual).

For **all spare part orders** (see references in the exploded view at the end of the manual), state:



- **the type,**
- **the machine serial number and**
- **the electrical specifications (16)**

recorded under the machine.

TROUBLE-SHOOTING



Identify the exact cause for stopping of the machine.
In all cases, if the problem persists, switch off the machine (disconnect the power cord (10)) and call a technician from the maintenance department or contact an approved SANTOS retailer.

The machine does not start

- Check: the mains power supply and the state of the power cord (10).
- Within the machine, check the state of the electric wires and connections (at the grommet (12), at the On/Off switch (13)) (fig. F).
- Check the electrical components and replace them one at a time (switch, capacitor, protective cover, starting relay, motor).

The machine stops at an overload

A foreign body in the bowl (3) or intense operation can result in an overload of the motor. Under these conditions, the over-current protection system (13) can go into action and stop the operation of the machine.

- See the "*motor overload safety*" part.

The motor makes noise

Check the tightening of the reduction gear (6). If the reduction gear is not correctly tightened, this results in premature wear of the reduction gear wheel and worm screw.
Note: Always replace the gear wheel and worm screw at the same time.

- Tighten the 2 reduction gear securing screws (4).

The bowl does not rotate

The bowl is not driven by the motor. It rotates under the dough mixing action. When mixing begins, it is necessary to help the bowl to turn manually. As soon as all the flour is "wet", the system operates alone and it is then necessary to brake the bowl to ensure correct mixing.

The bowl rotates too fast

To ensure correct mixing, it is necessary to brake the bowl.

- Turn the butterfly screw (5) located on the side of the bowl to lock it. And/or slow the rotation of the bowl by holding it with both hands.

The machine stops while mixing



- Check the correct position of the protective cover (1).
- If the bowl is overloaded (too much flour in the bowl), during rotation of the fork, too much stiff dough could gather around the fork and slightly raise the protective cover (1) thus stopping the machine.
- Clear the fork or lower the cover to start the motor.

Flour falls out of the bowl

If the bowl is too heavily loaded, before the flour is completely wet, a small quantity can be ejected from the bowl.

- Reduce the load (quantity of flour in the bowl).



TECHNICAL CHARACTERISTICS OF THE MACHINE

TECHNICAL CHARACTERISTICS

Model18		Single-phase	
Power supply voltage	(VAC)	220-240	100-120
Frequency	(Hz)	50/60	50/60
Motor: Power			
Power consumption	(W)	600	650
Motor speed:	(rpm)	1450 at 50Hz	1700 at 60Hz
Tool (fork) speed:	(rpm)	70 at 50Hz	84 at 60Hz
Bowl content	(l)		9.9
Maximum useful content of the bowl	(kg)		4
Dimensions: Height	(mm)		420
Width	(mm)		350
Depth	(mm)		500
Weight: Net weight	(kg)		17
Packed weight	(kg)		19
Noise: (2)	(dBA)		65

- (1) These values are given as an example. The exact electrical characteristics of your machine are noted on its identification plate.
- (2) Noise level measured as acoustic pressure of the machine under load at 1 m from its axis, according to standard EN 31201.

ELECTRICAL WIRING DIAGRAMS

Wiring diagram 100-120V~ 50/60Hz

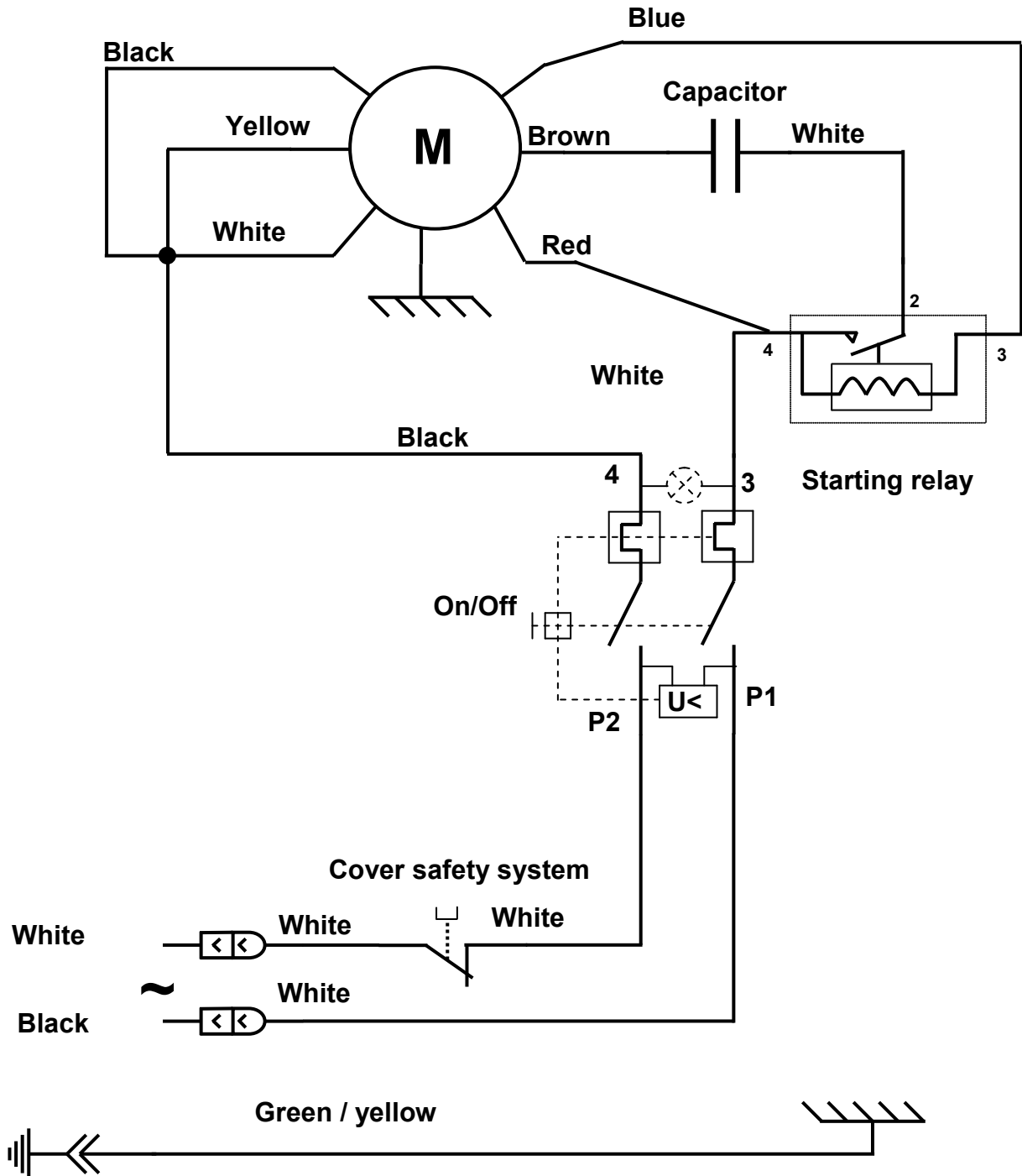

Wiring diagram 220-240V~ 50/60Hz

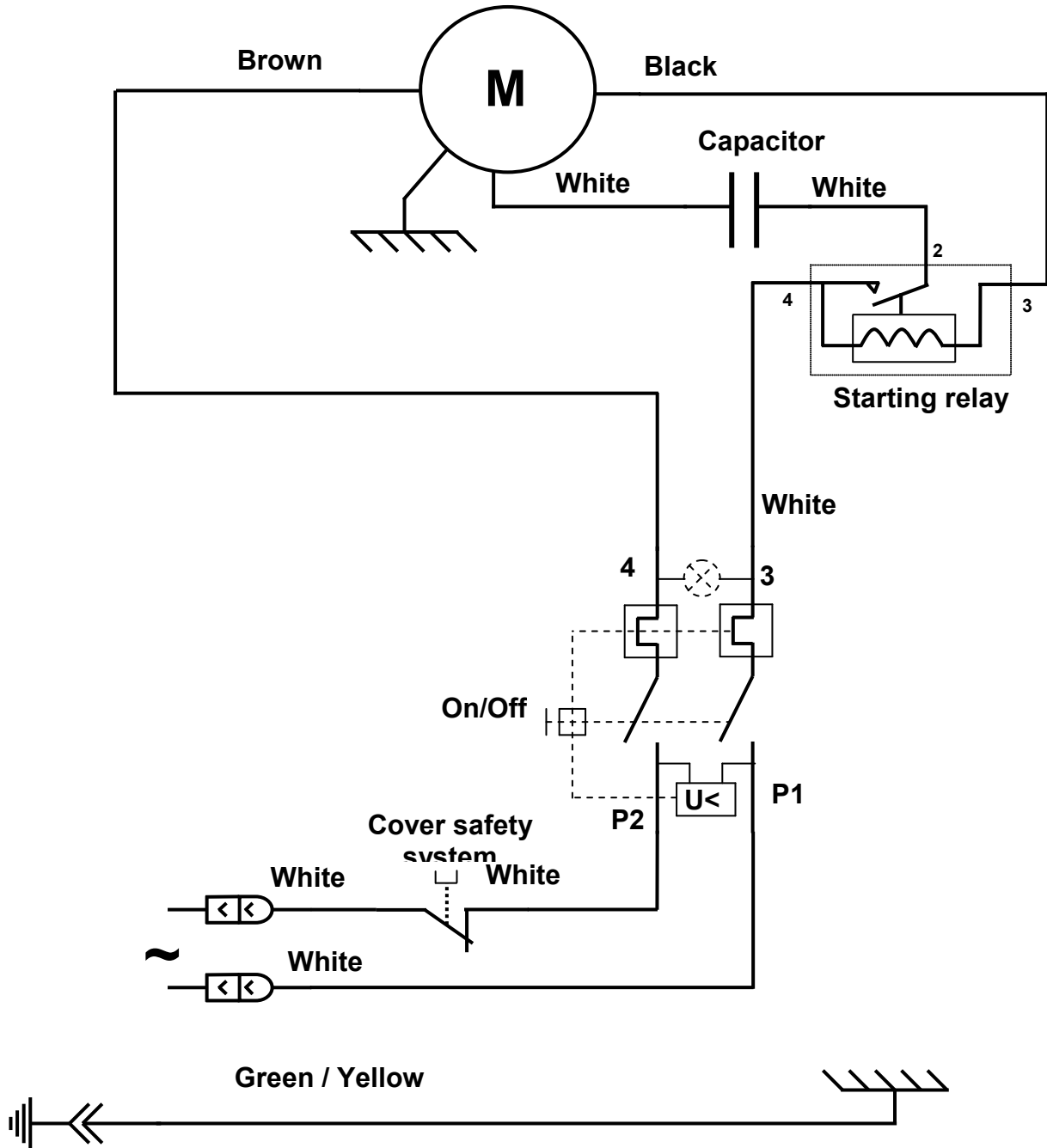



Component identification table

ITEM	Description
1	Protective cover
2	Lock ping
3	Bowl
4	Reduction gear securing screw
5	Adjustable brake
6	Reduction gear
7	Mixing fork
8	Base
9	Capacitor
10	Power cord
11	Identification plate
12	Grommet
13	Switch
14	Cover safety switch

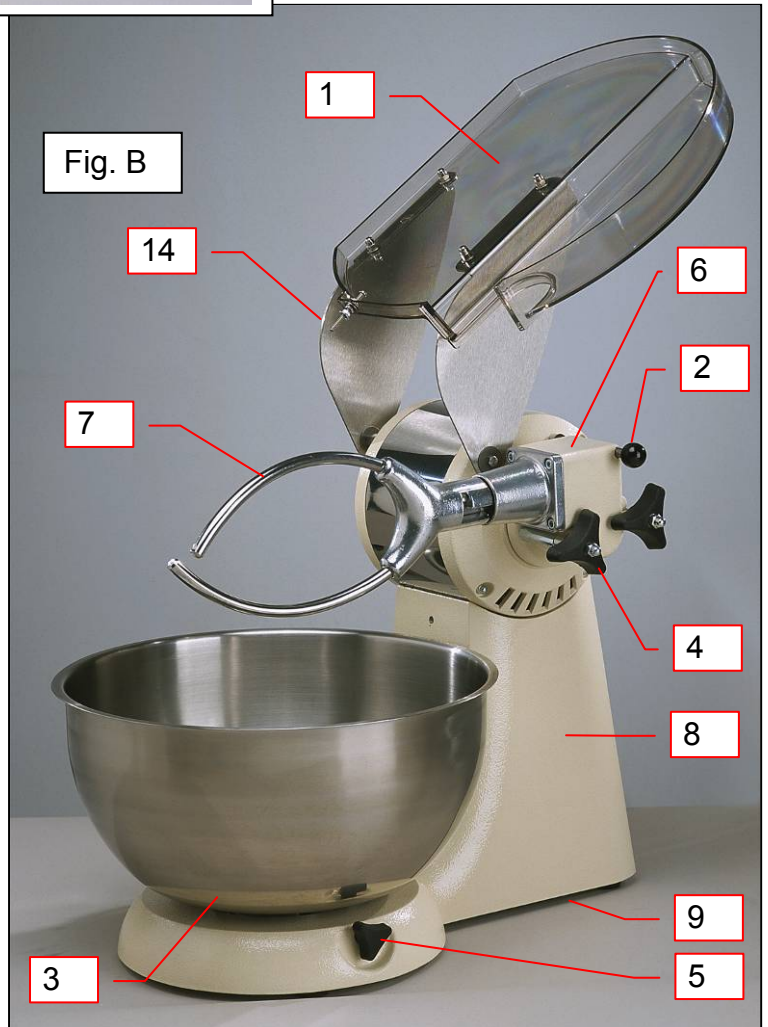
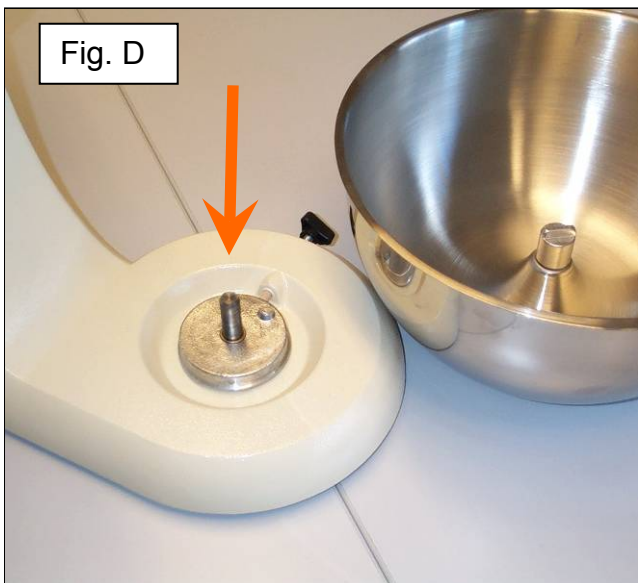
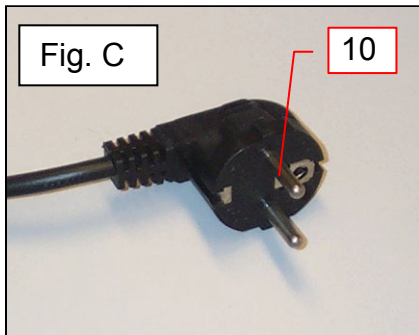

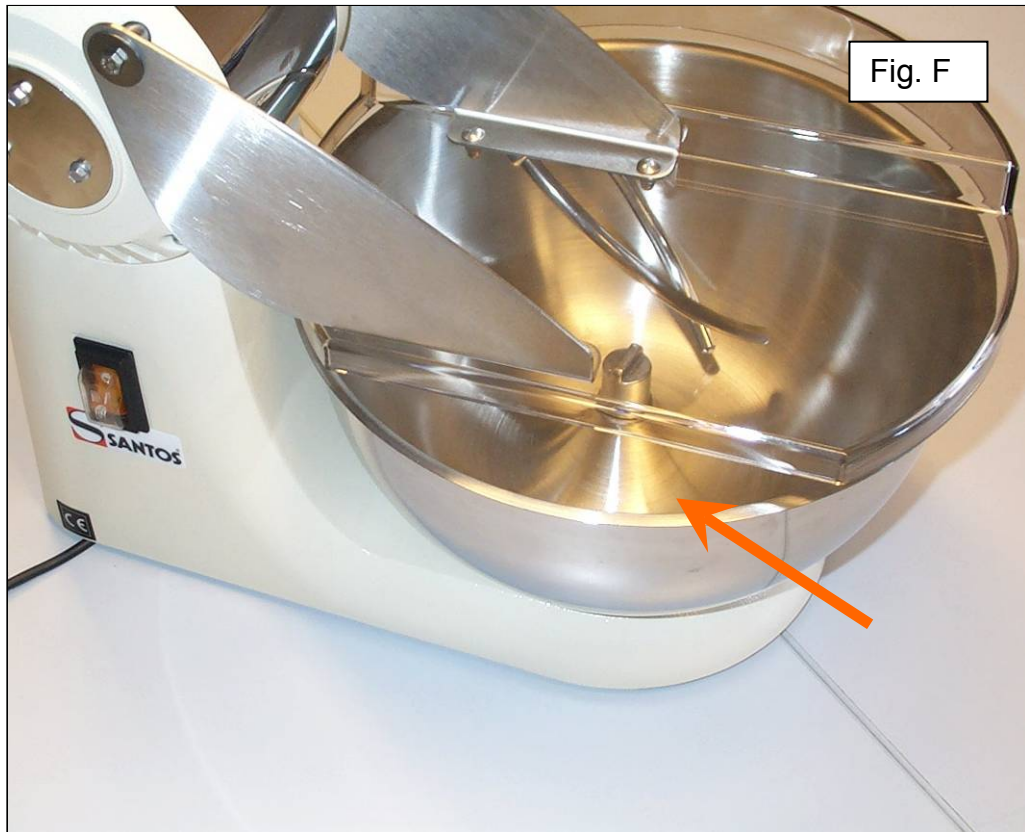
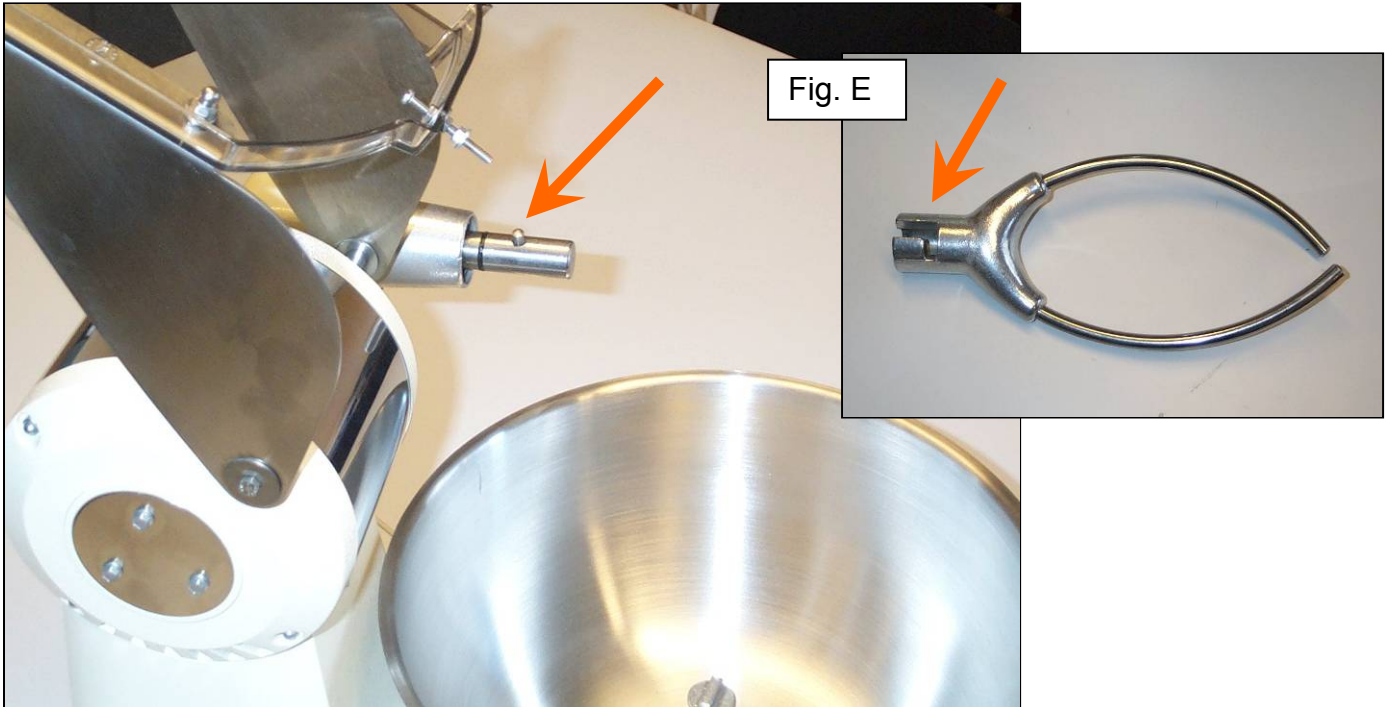

These photographs and images are given as an example and are non-contractual. Santos reserves the right to change them at any moment.



WARRANTY CERTIFICATE

WARRANTY

Since the 01.01.95, all our appliances comply with CE and possess the CE label. Our guarantee is of 24 months from the manufacturing date mentioned on the descriptive plate, except concerning the asynchronous motors (consisting of a rotor and a stator) which are warranted for 5 years from their manufacturing date. Warranty is strictly limited to the free replacement of any part of origin recognized by us as defective due to a defect or building default and identified as belonging to the concerned appliance. Warranty does not apply to damages resulting from installation or use non-complying with our appliance data sheet (user's manual) or in case of an evident lack of maintenance or disrespect of elementary security electric rules. It does not apply in case of regular wear and tear. Any replacement of parts under warranty will be realized after return of the defective part in our workshops, postage paid, supported by a copy of a conformity statement on which appears the serial number of the appliance. Every appliance is equipped with a descriptive plate conforming to the EC recommendations and of which a duplicate exists in the conformity statement (serial number, manufacturing date, electrical characteristics ...). In case of serious damage judged repairable only in our workshops, and after prior consent from our departments, any appliance under guarantee is sent by the Distributor, carriage paid. In case of repairs or reconditioning of appliances not under guarantee, the round trip transport is payable by the distributor. The parts and workforce are invoiced at the current rate. A preliminary estimate can be supplied.

Coffee grinder not using SANTOS original burrs are not taken under guarantee. The warranty conditions, repairs, reconditioning, of the espresso coffee grinder are the object of a specific note. Our guarantee does not extend to the payment of penalties, the repair of direct or indirect damages and notably to any loss of income resulting from the nonconformity or the defectiveness of products, SANTOS's global responsibility being limited to the sale price of the delivered product and to the possible repair of the defective products.

In case of revelation of an imperfection during the warranty period, the Distributor has to, unless a different written agreement of SANTOS, indicate to his customer to stop any use of the defective product. Such a use would release SANTOS of any responsibility.

APPLIANCE IDENTIFICATION PLATE

